



BUILT IN REFRIGERATORS Export Product Catalogue

Camlbee-USA Appliance

 High-end refrigerator manufacturing, overall kitchen appliance solutions, and refrigeration industry solutions.

Numerous advancements in technology point to Industry Leading Freshness.

CALMBEE-USA helps you enjoy your product longer with 0°C bio-preservation and is easy to clean.

Custom Panels, Stainless Elegance CALMBEE-USA provides new kitchen experiences to those who love life.

With easy installation of refrigerator and panels, CALMBEE-USA can partner with any level of sophistication.





Choose your life-style Enjoy the quality

CALMBEE-USA Built In Refrigerators

Drinking a cup of fresh milk while walking through the sitting room in the morning;
Serving fresh fruits for friends, who are sitting on the sofa in the afternoon;
Enjoying delicious seafood together with family in the evening.

CALMBEE-USA built in refrigerators and their advanced technology offers an European life style for years of enjoyment.

CALMBEE-USA
Much more than Industry Leading Freshness.

Luxury in Appearance
Luxury in Performance



European E energy labeling, authentic super energy saving

Almost all CALMBEE-USA built in refrigerators reach European E energy saving standard, through high efficiency compressor, optimized thermal-protective coating and refrigerating cycle to realize the energy saving goal. They are authentic energy saving pioneer, saving more energy and better in environmental protections. Making not bigger space consumes more energy, we have already considered more for your energy saving healthy life.



0°C bio-preservation extends freshness without freezing.

Magic cooling 0°C bio-preservation core technology has been adopted for built in models with a 100% independent crisper offering. 0°C bio-preservation, you can maximize humidity without freezing.



Mixture refrigerating/freezing with ultra-low frost technology makes you no hassle of manual removal of frost.

Normally, built in refrigerators need to be outage for defrosting at least twice a year, MAGICTEC built in refrigerators innovation adopting mixture refrigerating and freezing with ultra-low frost technologies, proving different solutions according to your demands, no hassle of repeated manual removal of frost, enjoying yourself for the leisure life.



Humidity crisper keeps foods fresher longer.

High-humidity independent crisper can easily adjust the humidity according to different food types which keeps fruits & vegetables fresh and tender. Higher fresh efficiency, better toasting foods.



Built in installation, matching your perfect kitchen
Offering a seamless design, CALMBEE-USA's impeccable characteristics let you create your kitchen your way.



Built in LED lamp design, gently lightens the interior space

New durable LED lamp is soft, perfectly and uniformly lightening the interior, meanwhile it is energy-efficient offering the right amount of light, at the right time.



Ergonomically design for your comfort

Flexible hinge with buffering makes you firmly and softly close the door

Buffer is integrated into the flat hinge, thus, even heavy doors can be easily firmly closed.

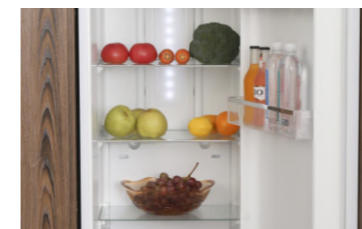

Adjustable stretch shelf, more space can be released

You just pull out the adjustable stretch shelf to conveniently access the foods, and easily adjust the height of the glass shelf and door rack. This optimizes fridge space and your ability to customize for your specific needs.



Built Under Larder /Fridge/Freezer

MSL 115BU MSF 85BU MSR 95BU



Capacity	▪ Loading Capacity(pcs/40HQ)	246	246	246
	▪ Total Net Capacity (L)	100	70	90
	▪ Fridge net capacity (L)	100	-	80
	▪ Freezer net capacity (L)	-	70	10
	▪ 4 star freezing	-	✓	-
Function controlling	▪ Controlling mode	Mechanical control	Mechanical control	Electronic control
	▪ Refrigerating cycle	Single cycle	Single cycle	Single cycle
	▪ Defrosting	Defrost	Defrost	Defrost
	▪ Fast cooling function	-	-	-
	▪ Fast freezing function	-	-	-
Others	▪ LED light	✓	-	✓
	▪ Refrigerant	R600a	R600a	R600a
	▪ Climate	N-T	N-T	N-T

MSL 115BU MSF 85BU MSF 95BU

- Rated Voltage: 220-240V
 - Available power cable length: 150cm
 - Reversible door
- Cabinet dimension(H×W×Dmm): 830×530×590
 ▪ Product dimension(H×W×Dmm): 810×500×560

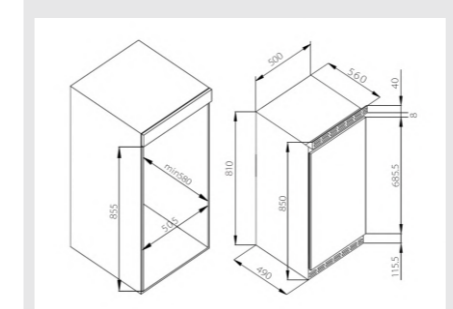

unit : (mm)

- Rated Voltage: 220-240V
 - Available power cable length: 150cm
 - Reversible door
- Cabinet dimension(H×W×Dmm): 830×530×590
 ▪ Product dimension(H×W×Dmm): 810×500×560

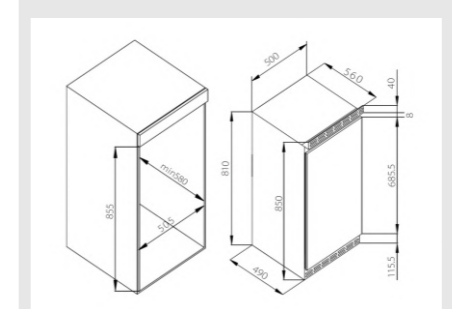

unit : (mm)

- Rated Voltage: 220-240V
 - Available power cable length: 150cm
 - Reversible door
- Cabinet dimension(H×W×Dmm): 830×530×590
 ▪ Product dimension(H×W×Dmm): 810×500×560

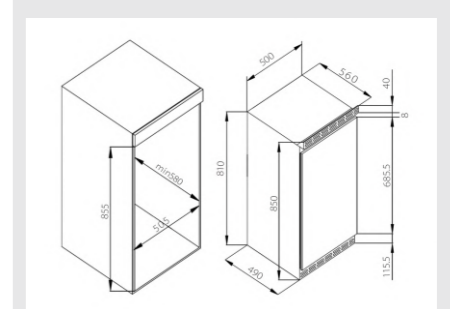

unit : (mm)

• Detailed contents in kind prevail

Built Under Larder /Fridge/Freezer

MSL 110BU

MSF 90BU

MSR 100BU



Capacity	▪ Loading Capacity(pcs/40HQ)	210	210	210
	▪ Total Net Capacity (L)	110	90	100
	▪ Fridge net capacity (L)	110	-	87
	▪ Freezer net capacity (L)	-	90	13
	▪ 4 star freezing	-	✓	-
Function controlling	▪ Controlling mode	Mechanical control Electronic control	Mechanical control Electronic control	Mechanical control Electronic control
	▪ Refrigerating cycle	Single cycle	Single cycle	Single cycle
	▪ Defrosting	Defrost	Defrost	Defrost
	▪ Fast cooling function	✓	-	✓
	▪ Fast freezing function	-	✓	-
Others	▪ LED light	✓	-	✓
	▪ Refrigerant	R600a	R600a	R600a
	▪ Climate	N-T	N-T	N-T

Built-in Larder /Fridge/Freezer

MSR118EBI

MSR188EBI

MSR228EBI



Capacity	Loading Capacity (pcs/40HQ)	212	160	144
	Total Net Capacity (L)	118	188	228
	Fridge net capacity (L)	102	172	212
	Freezer net capacity (L)	16	16	16
	4 star freezing	-	-	-
Function controlling	Controlling mode	Electrical control	Electrical control	Electrical control
	Refrigerating cycle	Single cycle	Single cycle	Single cycle
	Defrosting	Defrost	Defrost	Defrost
	Fast cooling function	-	-	-
	Fast freezing function	-	-	-
Others	LED light	✓	✓	✓
	Refrigerant	R600a	R600a	R600a
	Climate	N-T	N-T	N-T

MSL 110BU

MSF 90BU

MSR 100BU

- Rated Voltage: 220-240V
- Available power cable length: 150cm
- Reversible door

- Cabinet dimension(H×W×Dmm): 830×605×550
- Product dimension(H×W×Dmm): 820×595×545

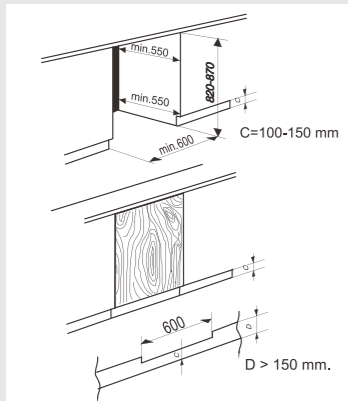

unit : (mm)

- Rated Voltage: 220-240V
- Available power cable length: 150cm
- Reversible door

- Cabinet dimension(H×W×Dmm): 830×605×550
- Product dimension(H×W×Dmm): 820×595×545

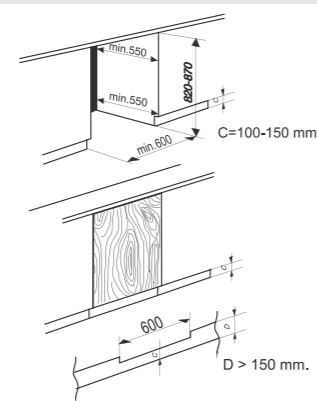

unit : (mm)

- Rated Voltage: 220-240V
- Available power cable length: 150cm
- Reversible door

- Cabinet dimension(H×W×Dmm): 830×605×550
- Product dimension(H×W×Dmm): 820×595×545

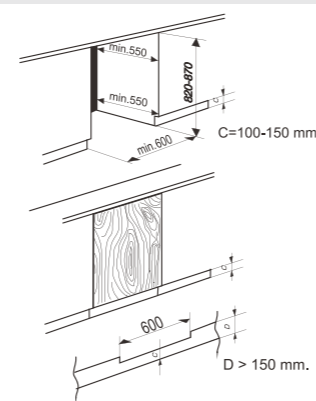

unit : (mm)

• Detailed contents in kind prevail

MSR118EBI

MSR188EBI

MSR228EBI

- Rated Voltage: 220-240V
- Available power cable length: 150cm
- Reversible door

- Cabinet dimension(H×W×Dmm): 874×574×560
- Product dimension(H×W×Dmm): 872×558×545

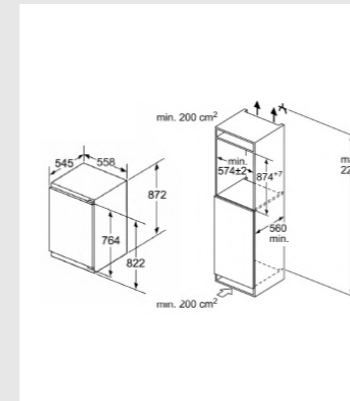

unit : (mm)

- Rated Voltage: 220-240V
- Available power cable length: 180cm
- Reversible door

- Cabinet dimension(H×W×Dmm): 1221×574×560
- Product dimension(H×W×Dmm): 1220×558×545

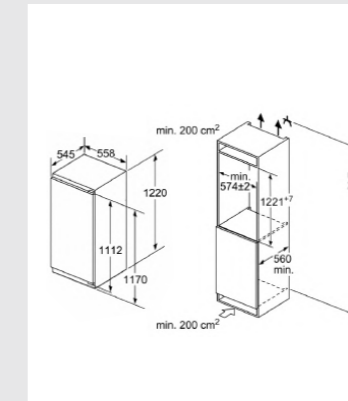

unit : (mm)

- Rated Voltage: 220-240V
- Available power cable length: 180cm
- Reversible door

- Cabinet dimension(H×W×Dmm): 1397×574×560
- Product dimension(H×W×Dmm): 1395×558×545

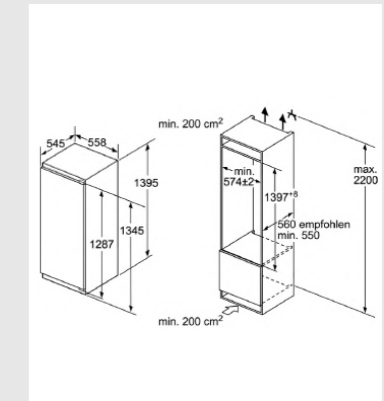

unit : (mm)

• Detailed contents in kind prevail

Built-in Fridge Freezer(defrost)

MDRF 222BI -N

MDRF 229BI -N



Capacity	▪ Loading Capacity(pcs/40HQ)	105	105
	▪ Total Net Capacity (L)	222	229
	▪ Fridge net capacity (L)	156	181
	▪ Freezer net capacity (L)	66	48
	▪ 4 star freezing	✓	✓
Function controlling	▪ Controlling mode	Mechanical control	Mechanical control
	▪ Refrigerating cycle	Single cycle	Single cycle
	▪ Defrosting	Defrost	Defrost
	▪ Fast cooling function	✓	✓
	▪ Fast freezing function	✓	✓
Others	▪ LED light	✓	✓
	▪ Refrigerant	R600a	R600a
	▪ Climate	N-T	N-T

Built-in Fridge Freezer(frost free)

MDRF 216WBI -N

MDRF 225WBI -N



Capacity	▪ Loading Capacity(pcs/40HQ)	105	105
	▪ Total Net Capacity (L)	216	225
	▪ Fridge net capacity (L)	156	181
	▪ Freezer net capacity (L)	60	44
	▪ 4 star freezing	✓	✓
Function controlling	▪ Controlling mode	Mechanical control	Mechanical control
	▪ Refrigerating cycle	Single cycle	Single cycle
	▪ Defrosting	Frost free	Frost free
	▪ Fast cooling function	✓	✓
	▪ Fast freezing function	✓	✓
Others	▪ LED light	✓	✓
	▪ Refrigerant	R600a	R600a
	▪ Climate	N-T	N-T

MDRF 222BI -N

MDRF 229BI -N

- Rated Voltage: 220 - 240V
- Available power cable length: 200cm
- Reversible door
- Cabinet dimension(H×W×Dmm): 1782×573×560
- Product dimension(H×W×Dmm): 1770×540×545

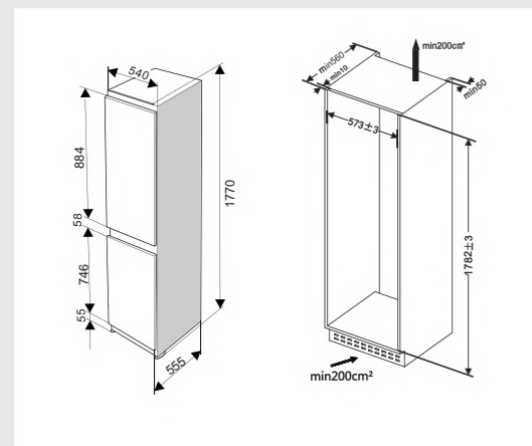

unit : (mm)

- Rated Voltage: 220 - 240V
- Available power cable length: 200cm
- Reversible door
- Cabinet dimension(H×W×Dmm): 1782×573×560
- Product dimension(H×W×Dmm): 1770×540×545

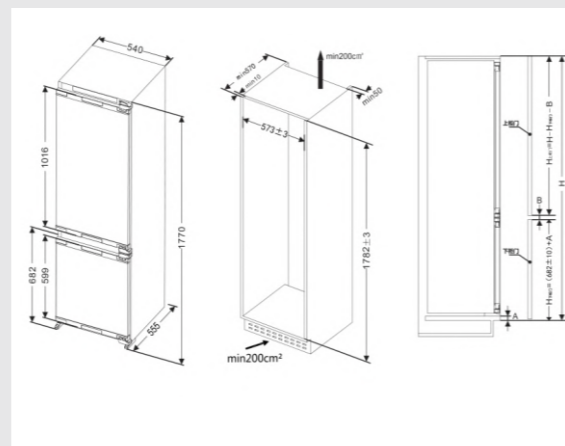

unit : (mm)

• Detailed contents in kind prevail

MDRF 216WBI -N

MDRF 225WBI -N

- Rated Voltage: 220 - 240V
- Available power cable length: 200cm
- Reversible door
- Cabinet dimension(H×W×Dmm): 1782×573×560
- Product dimension(H×W×Dmm): 1770×540×545

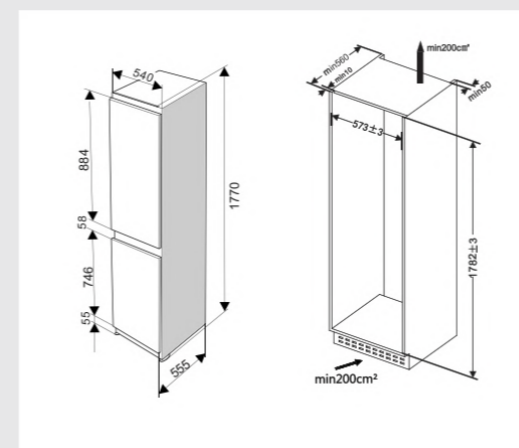

unit : (mm)

- Rated Voltage: 220 - 240V
- Available power cable length: 200cm
- Reversible door
- Cabinet dimension(H×W×Dmm): 1782×573×560
- Product dimension(H×W×Dmm): 1770×540×545

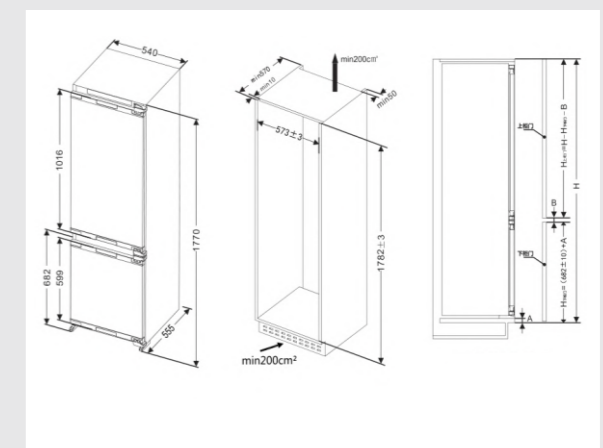

unit : (mm)

• Detailed contents in kind prevail

Built-in Fridge Freezer(frost free)

MDRF 241WEBI

MDRF241WEBI PRO

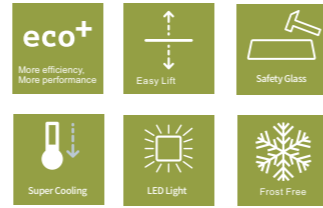
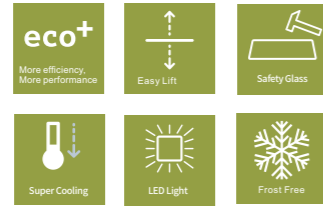

Capacity	▪ Loading Capacity(pcs/40HQ)	105	105
	▪ Total Net Capacity (L)	241	241
	▪ Fridge net capacity (L)	184	184
	▪ Freezer net capacity (L)	57	57
	▪ 4 star freezing	✓	✓
Function controlling	▪ Controlling mode	Electrical control	Electrical control
	▪ Refrigerating cycle	Single cycle	Single cycle
	▪ Defrosting	Frost free	Frost free
	▪ Fast cooling function	✓	✓
	▪ Fast freezing function	-	-
Others	▪ LED light	✓	LED surface light
	▪ Refrigerant	R600a	R600a
	▪ Climate	N-T	N-T

Built-in Fridge Freezer(frost free)

MDRF250WEBI

MDRF250WEBI PRO



Capacity	▪ Loading Capacity(pcs/40HQ)	105	105
	▪ Total Net Capacity (L)	238	238
	▪ Fridge net capacity (L)	169	169
	▪ Freezer net capacity (L)	69	69
	▪ 4 star freezing	✓	✓
Function controlling	▪ Controlling mode	Electrical control	Electrical control
	▪ Refrigerating cycle	Single cycle	Single cycle
	▪ Defrosting	Frost free	Frost free
	▪ Fast cooling function	✓	✓
	▪ Fast freezing function	✓	✓
Others	▪ LED light	✓	LED surface light
	▪ Refrigerant	R600a	R600a
	▪ Climate	N-T	N-T

MDRF 241WEBI

MDRF241WEBI PRO

- Rated Voltage: 220 - 240V
- Available power cable length: 200cm
- Reversible door
- Cabinet dimension(H×W×Dmm): 1776×558×570
- Product dimension(H×W×Dmm): 1770×540×555

- Rated Voltage: 220 - 240V
- Available power cable length: 200cm
- Reversible door
- Cabinet dimension(H×W×Dmm): 1776×558×570
- Product dimension(H×W×Dmm): 1770×540×555

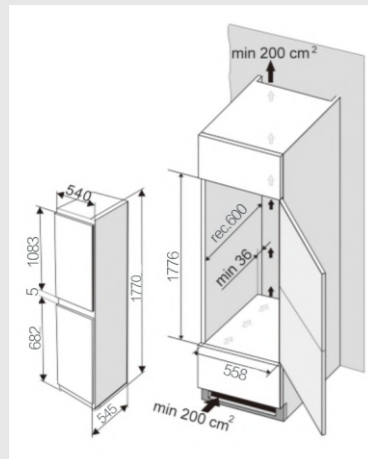

unit : (mm)

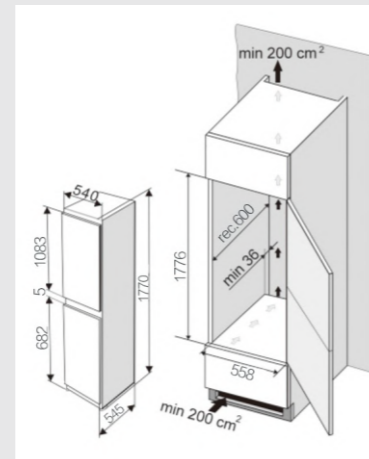

unit : (mm)

• Detailed contents in kind prevail

MDRF250WEBI

MDRF250WEBI PRO

- Rated Voltage: 220 - 240V
- Available power cable length: 200cm
- Reversible door
- Cabinet dimension(H×W×Dmm): 1776×558×560
- Product dimension(H×W×Dmm): 1770×540×545

- Rated Voltage: 220 - 240V
- Available power cable length: 200cm
- Reversible door
- Cabinet dimension(H×W×Dmm): 1776×558×560
- Product dimension(H×W×Dmm): 1770×540×545

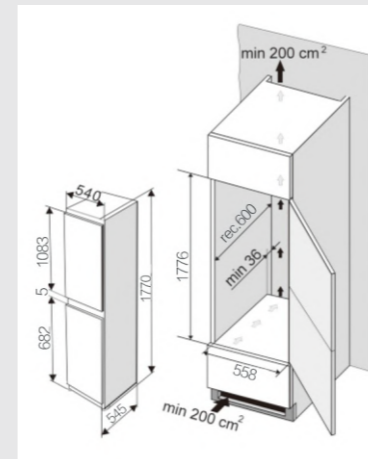

unit : (mm)

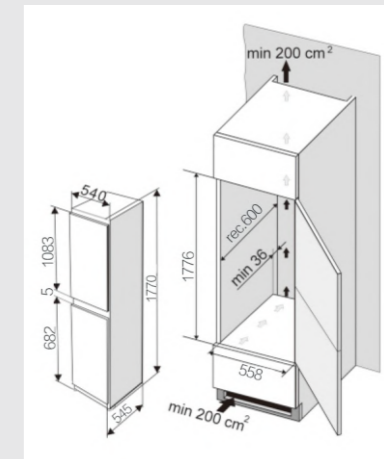

unit : (mm)

• Detailed contents in kind prevail

Built-in Fridge Freezer(frost free)

MDRF310WEBI

MDRF310WEBI PRO



Capacity	▪ Loading Capacity(pcs/40HQ)	103	103
	▪ Total Net Capacity (L)	310	310
	▪ Fridge net capacity (L)	248	248
	▪ Freezer net capacity (L)	62	62
	▪ 4 star freezing	✓	✓
Function controlling	▪ Controlling mode	Electronic control	Electronic control
	▪ Refrigerating cycle	Single cycle	Single cycle
	▪ Defrosting	Frost free	Frost free
	▪ Fast cooling function	✓	✓
	▪ Fast freezing function	-	-
Others	▪ LED light	✓	LED surface light
	▪ Refrigerant	R600a	R600a
	▪ Climate	N-T	N-T

Built-in Fridge Freezer(frost free)

MDRF305WEBI

MDRF305WEBI PRO



Capacity	▪ Loading Capacity(pcs/40HQ)	103	103
	▪ Total Net Capacity (L)	305	305
	▪ Fridge net capacity (L)	243	243
	▪ Freezer net capacity (L)	62	62
	▪ 4 star freezing	✓	✓
Function controlling	▪ Controlling mode	Electronic control	Electronic control
	▪ Refrigerating cycle	Single cycle	Single cycle
	▪ Defrosting	Frost free	Frost free
	▪ Fast cooling function	✓	✓
	▪ Fast freezing function	✓	✓
Others	▪ LED light	✓	LED surface light
	▪ Refrigerant	R600a	R600a
	▪ Climate	N-T	N-T

MDRF310WEBI

MDRF310WEBI PRO

- Rated Power:180W ▪ Rated Voltage:220 - 240V
- Available power cable length: 200cm ▪ Reversible door
- Cabinet dimension(H×W×Dmm): 1952×573×570
- Product dimension(H×W×Dmm): 1940×540×555

- Rated Power:180W ▪ Rated Voltage:220 - 240V
- Available power cable length: 200cm ▪ Reversible door
- Cabinet dimension(H×W×Dmm): 1952×573×570
- Product dimension(H×W×Dmm): 1940×540×555

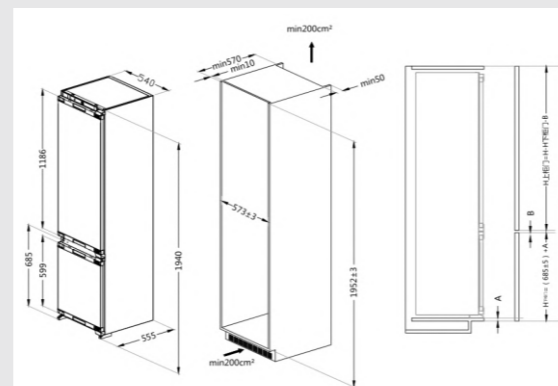
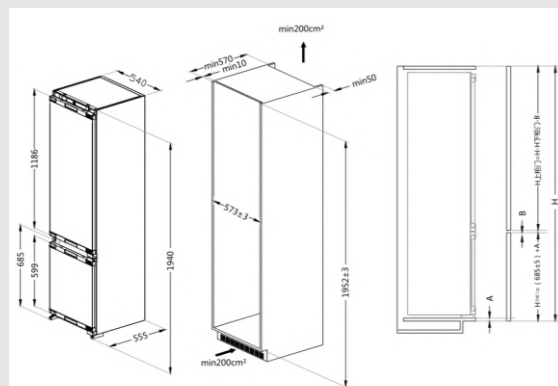

unit : (mm)

unit : (mm)

• Detailed contents in kind prevail

MDRF305WEBI

MDRF305WEBI PRO

- Rated Power:160W ▪ Rated Voltage:220 - 240V
- Available power cable length: 200cm ▪ Reversible door
- Cabinet dimension(H×W×Dmm): 1952×573×570
- Product dimension(H×W×Dmm): 1940×540×555

- Rated Power:160W ▪ Rated Voltage:220 - 240V
- Available power cable length: 200cm ▪ Reversible door
- Cabinet dimension(H×W×Dmm): 1952×573×570
- Product dimension(H×W×Dmm): 1940×540×555

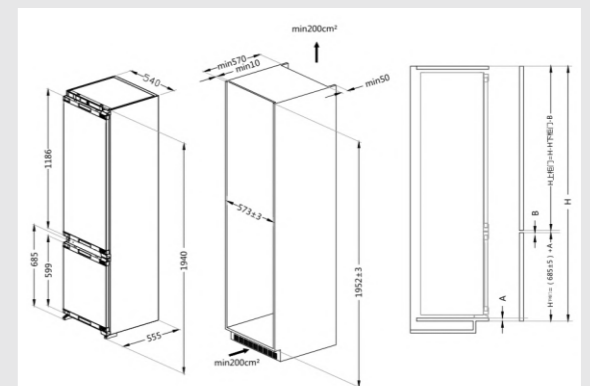
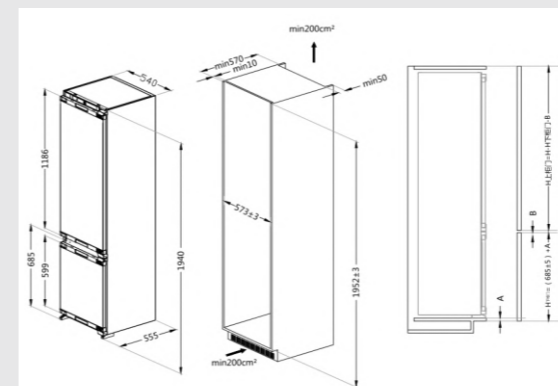

unit : (mm)

unit : (mm)

• Detailed contents in kind prevail

Built-in Fridge Freezer(frost free)

MDRF 375WEBI

MSRF250WEBI

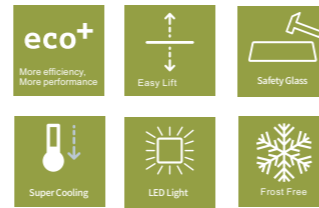

Capacity	▪ Loading Capacity(pcs/40HQ)	84	105
	▪ Total Net Capacity (L)	375	238
	▪ Fridge net capacity (L)	280	169
	▪ Freezer net capacity (L)	95	69
	▪ 4 star freezing	✓	✓
Function controlling	▪ Controlling mode	Electronic control	Electrical control
	▪ Refrigerating cycle	Single cycle	Single cycle
	▪ Defrosting	Frost free	Frost free
	▪ Fast cooling function	✓	✓
	▪ Fast freezing function	✓	-
Others	▪ LED light	✓	✓
	▪ Refrigerant	R600a	R600a
	▪ Climate	N-T	N-T

Built-in Upright Fridge / Freezer(frost free)

MSF 230WEBI

MSL 330WEBI



Capacity	▪ Loading Capacity(pcs/40HQ)	105	105
	▪ Total Net Capacity (L)	208	260
	▪ Fridge net capacity (L)	-	260
	▪ Freezer net capacity (L)	208	-
	▪ 4 star freezing	✓	-
Function controlling	▪ Controlling mode	Electronic control	Electronic control
	▪ Refrigerating cycle	Single cycle	Single cycle
	▪ Defrosting	Frost free	Frost free
	▪ Fast cooling function	-	✓
	▪ Fast freezing function	✓	-
Others	▪ LED light	-	✓
	▪ Refrigerant	R600a	R600a
	▪ Climate	N-T	N-T

MDRF 375WEBI

MSRF250WEBI

- Rated Power:160W ▪ Rated Voltage:220 - 240V
- Available power cable length: 200cm ▪ Reversible door
- Cabinet dimension(H×W×Dmm): 1920×715×560
- Product dimension(H×W×Dmm): 1915×700×545

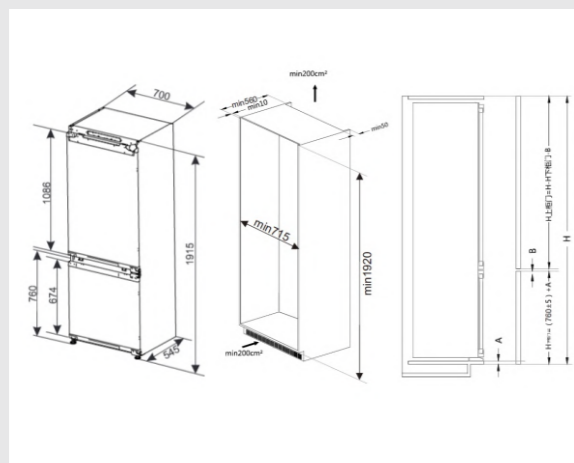

unit : (mm)

- Rated Voltage: 220-240
- Available power cable length: 200cm Reversible door
- Cabinet dimension(H×W×Dmm): 1782×573×560
- Product dimension(H×W×Dmm): 1770×540×545

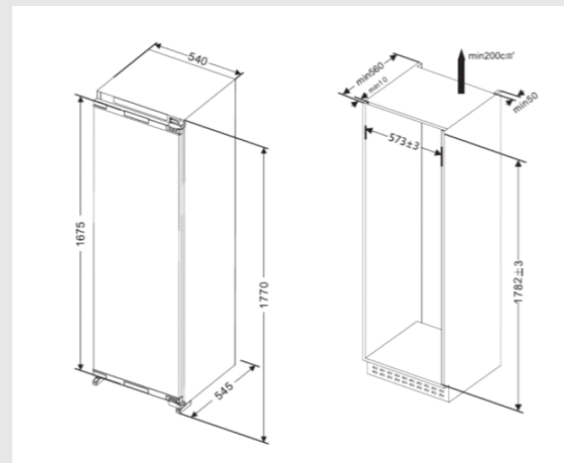

unit : (mm)

MSF 230WEBI

MSL 330WEBI

- Rated Power:160W ▪ Rated Voltage:220 - 240V
- Available power cable length: 200cm ▪ Reversible door
- Cabinet dimension(H×W×Dmm): 1776×558×560
- Product dimension(H×W×Dmm): 1770×540×545

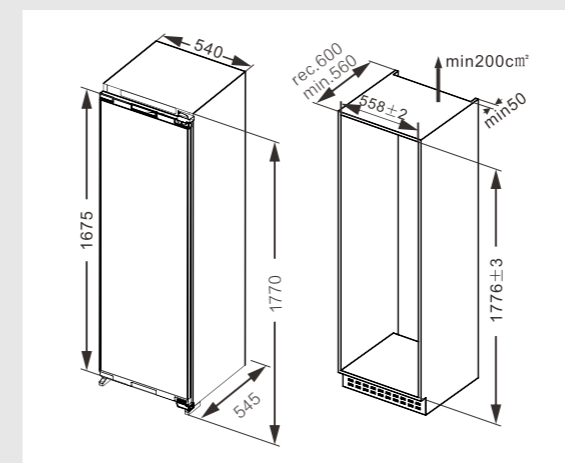

unit : (mm)

- Rated Power:180W ▪ Rated Voltage:220 - 240V
- Available power cable length: 200cm ▪ Reversible door
- Cabinet dimension(H×W×Dmm): 1776×558×560
- Product dimension(H×W×Dmm): 1770×540×545

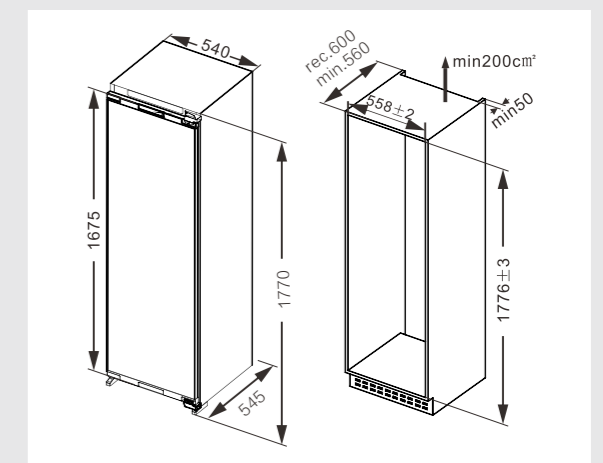

unit : (mm)

• Detailed contents in kind prevail

• Detailed contents in kind prevail

Built-in Wine Cellar (frost free)

ACWC053B

ACWC088B



Capacity	▪ Loading Capacity(pcs/40HQ)	215	105
	▪ Total Net Capacity (L)	122	260
	▪ Fridge net capacity (L)	122	260
	▪ Freezer net capacity (L)	0	0
	▪ 4 star freezing	-	-
Function controlling	▪ Controlling mode	Electronic control	Electronic control
	▪ Refrigerating cycle	Single cycle	Single cycle
	▪ Defrosting	Frost free	Frost free
	▪ Fast cooling function	-	-
	▪ Fast freezing function	-	-
Others	▪ LED light	✓	✓
	▪ Refrigerant	R600a	R600a
	▪ Climate	N-T	N-T

Built-in Wine Cellar (frost free)

MSL140WEG-GM



Capacity	▪ Loading Capacity(pcs/40HQ)	202	
	▪ Total Net Capacity (L)	140	
	▪ Fridge net capacity (L)	140	
	▪ Freezer net capacity (L)	-	
	▪ 4 star freezing	-	
Function controlling	▪ Controlling mode	Electrical control	
	▪ Refrigerating cycle	Single cycle	
	▪ Defrosting	Frost free	
	▪ Fast cooling function	-	
	▪ Fast freezing function	-	
Others	▪ LED light	✓	
	▪ Refrigerant	R600a	
	▪ Climate	N-T	

ACWC053B

ACWC088B

- Rated Power:180W
- Rated Voltage:220 - 240V
- Available power cable length: 200cm

- Cabinet dimension(H×W×Dmm): 825×640×570
- Product dimension(H×W×Dmm): 790×595×537

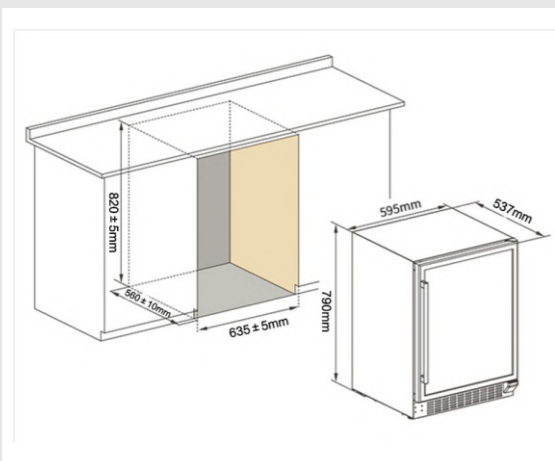

unit : (mm)

- Rated Power:160W
- Rated Voltage:220 - 240V
- Available power cable length: 200cm

- Cabinet dimension(H×W×Dmm): 1785×576×560
- Product dimension(H×W×Dmm): 1770×540×545

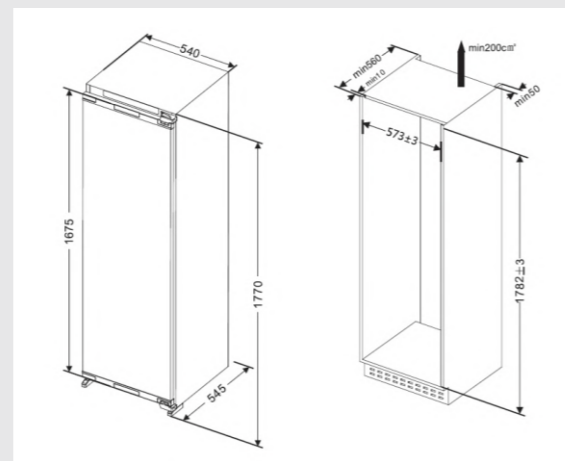

unit : (mm)

• Detailed contents in kind prevail

MSL140WEG-GM

- Rated Power: 150W
- Rated Voltage: 220-240V
- Available power cable length: 200cm
- Reversible door

- Cabinet dimension(H×W×Dmm): 890×570×530
- Product dimension(H×W×Dmm): 906×595×542

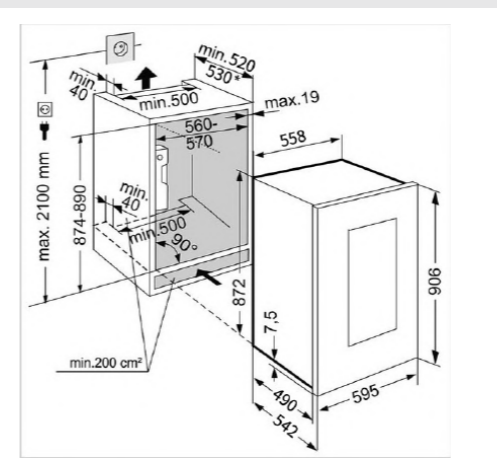

unit : (mm)

• Detailed contents in kind prevail

