

Calmbee



BUILT-IN ELECTRIC OVEN

EB-125ERC3

How to keep Your Oven in Shape

This appliance is for household use only, don't use it outdoors!

Important: Before cleaning your oven, or performing maintenance, disconnect it from the power supply.

To extend the life of your oven, it must be cleaned frequently, keeping in mind that:

- ⊙ **Do not use steam equipment to clean the appliance?**
- ⊙ To protect against the risk of electrical shock, do not immerse the unit, cord or plug in water or other liquid or sprinkle water to clean the appliance!
- ⊙ Don't clean the appliance when it still hot! The inside and external surface of the oven should preferably be cleaned by damp cloth when it is cooled down.
- ⊙ Wash all accessories in hot sudsy water or in a dishwasher, wipe dry with a paper or cloth towel.
- ⊙ If you use your oven for an extended period of time, condensation may form. Dry it using a soft cloth.
- ⊙ There is a rubber seal surrounding the oven opening which guarantees its perfect functioning. Check the condition of this seal on a regular basis. If necessary, clean it and avoid using abrasive products or objects to do so. Should it become damaged, please contact your nearest After-sales Service Centre. We recommend you avoid using the oven until it has been repaired.
- ⊙ Never line the oven bottom with aluminium foil, as the consequent accumulation of heat could compromise the cooking and even damage the enamel.
- ⊙ Clear the glass door using damp cloth and dry it with a soft cloth..

Do not use harsh abrasive cleaners or sharp metal scrapers to clean the oven door glass since they can scratch the surface, which may result in shattering of the glass.

Replacing the Lamp in the Oven

- ⊙ Cut off the supply of power to the oven by turning off the omni-polar switch connecting it to the mains, or by removing the plug if it is accessible; Avoids appearing the electric shock;
- ⊙ Unscrew the glass cover attached to the lamp holder;
- ⊙ Pull out the lamp and replace it with another high-temperature lamp (300°C) with the following characteristics:

- Voltage: AC230V
- Wattage: 25W
- Socket: G9

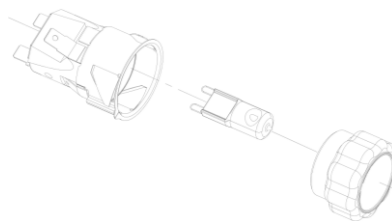

- ⊙ Remount the glass cover and reconnect the appliance to the power supply.

WARNING: Ensure that the appliance is switched off before replacing the lamp to avoid the possibility of electric shock.

Warning: Do not operate appliance with damaged cord or plug or after the appliance malfunctions, or has been damaged in any manner, return appliance to the nearest Authorized Service Center for examination. Repair, or adjustment!

The following maintenance should be by Authorized Service Center or similarly qualified persons in order to avoid a hazard!

Cleaning the oven door

To make it easier to clean the inside of your oven, the oven door can be removed, by proceeding as follows (fig. 1-2):

- Open the door completely and lift the 2 levers “B” (fig.1);
- Now, shutting the door slightly, you can lift it out by pulling out the hooks “A” as shown in figure 2.

To reassemble the door:

- With the door in a vertical position, insert the two hooks “A” into the slots;
- Ensure that seat “D” is hooked perfectly onto the edge of the slot (move the oven door backwards and forward slightly);
- Keep the oven door open fully, unhook the 2 levers “B” downwards and then shut the door again.

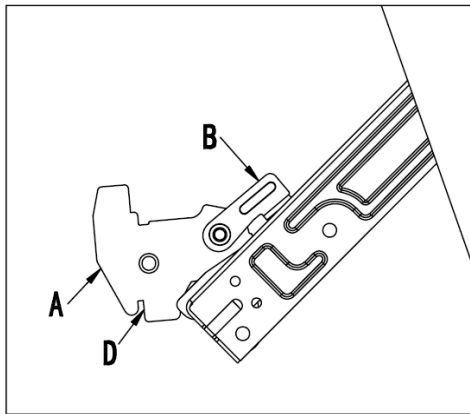

Fig. 1

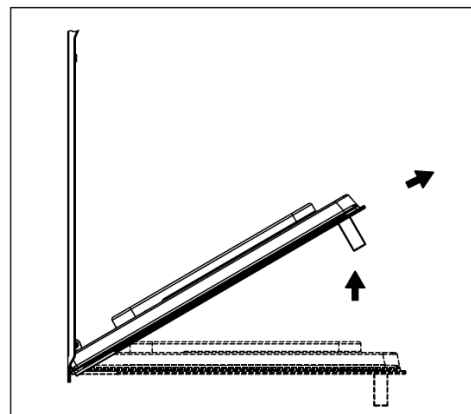

Fig. 2



This product must not be disposed together with the domestic waste. This product has to be disposed at an authorized place for recycling of electrical and electronic appliances.

By collecting and recycling waste, you help save natural resources, and make sure the product is disposed in an environmental friendly and healthy way.

Fastening the oven

Insert the appliance into the compartment; open the oven door and fasten the oven to the cabinet using the four screws “A”, remembering to place the special spacers provided between the hole and the screw itself.

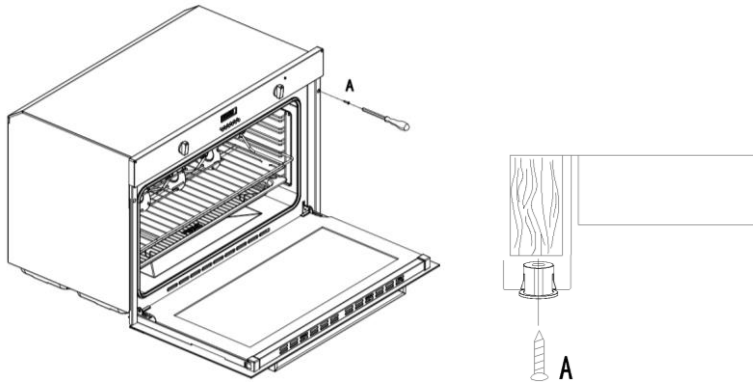
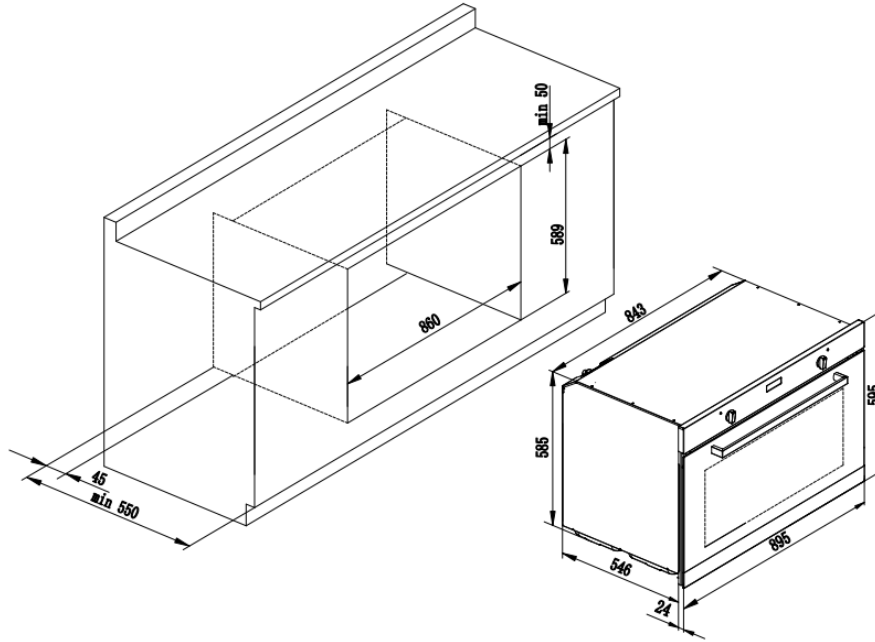

Installation

Important: the power supply to the appliance must be cut off before any adjustments or maintenance work is done on it.

Installation of Built-in Ovens

To ensure the proper working order of the built-in appliance, the kitchen unit must be of a suitable size. The sizes of the unit for installing the cooker under a worktop or in a column unit are shown in figure.

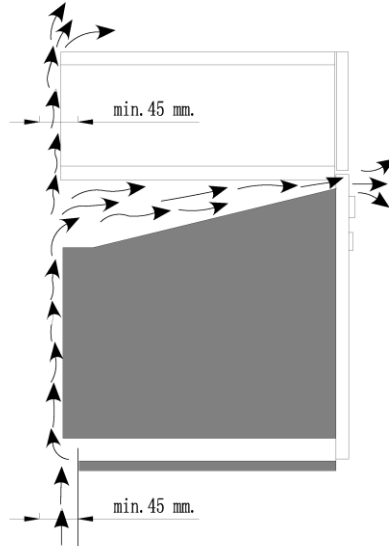

To provide adequate ventilation, there must be appropriate ventilation openings in the front bottom and the top part of 200 cm², and an exhaust opening on the bottom of an least 200 cm², and an exhaust opening of at least 60 cm².

The unit panels next to the cooker must be heat resistant. In the case of veneered wood units, glues must be resistant to a temperature of 120°C.

In accordance with safety standards, once the appliance has been mounted, there must be no possible contact with electrical parts. Any protective parts must be secured so that they can only be removed with the use of tools.

Electrical connection

Ovens equipped with a three-power supply cable are designed to operate with alternating current at the voltage and frequency indicated on the data plate located on the appliance (see below).

Fitting the power supply cable

1. Open the terminal board by inserting a screwdriver into the side tabs of the cover. Use the screwdriver as a lever by pushing it down to open the cover (see diagram).
2. Install the power supply cable by loosening the cable clamp screw and the three wire contact screws LNConnect the wires to the corresponding terminals: the Blue wire to the terminal marked (N), the Brown wire to the terminal marked (L) and the Yellow/Green wire to the terminal marked (see diagram).
3. Secure the cable by fastening the clamp screw.
4. Close the cover of the terminal board.

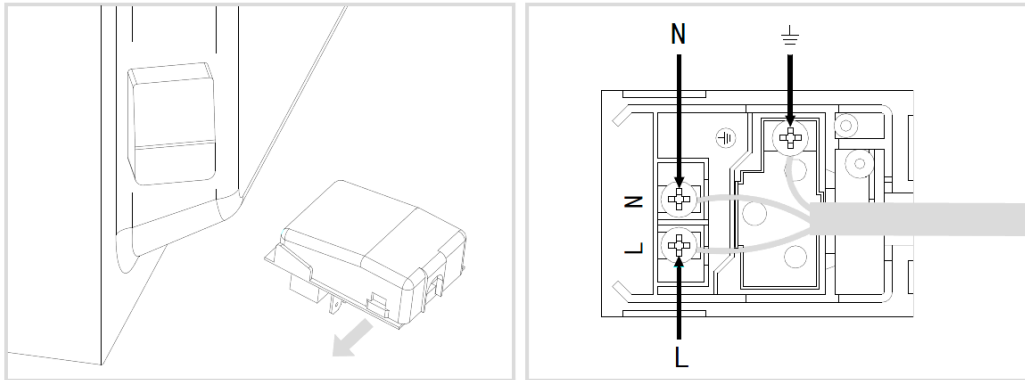

Connecting the electricity supply cable to the mains

1. Cable must be connected to power supply cable through power switch.
2. Rated current of power switch must be higher than 16A.
3. Ambient temperature of power supply cable cannot exceed 50 degrees.
4. Once oven is installed, power switch should be cut off easily.
5. The cable must not be bent or compressed.
6. The cable must be checked regularly and replaced by authorised technicians only (see Assistance).

The disconnection may be achieved by having the plug accessible or by incorporating a switch in the fixed wiring in accordance with the wiring rules.

Safety Is A Good Habit To Get Into

- ⊙ This appliance is designed for non-professional, household use and its functions must not be changed.
- ⊙ The electrical system of this appliance may be used safely only when it is correctly connected to an efficient earthing system in compliance with the safety standards currently in effect.
- ⊙ The manufacturer will not be held liable for any damages that might arise out of incorrect installation or improper, incorrect or unreasonable use of the appliance.

The following items are potentially dangerous, and, therefore, appropriate measures must be taken to prevent children and the disabled from coming into contact with them:

- Controls and the appliance in general;
- Packaging (bags, polystyrene, nails, etc.);
- The appliance immediately after use of the oven or grill due to the heat generated;
- The appliance when no longer in use (potentially dangerous parts must be made safe).

Avoid the following:

- Touching the appliance with wet parts of the body;
- Using the appliance when barefoot;
- Pulling on the appliance or the supply cord to unplug it from the electrical outlet;
- Obstructing the ventilation or heat dissipation slots;
- Allowing power supply cords for small appliances to come into contact with the hot parts of the appliance;
- Exposing the appliance to atmospheric agents (rain, sun);
- Using the oven for storage purposes;
- Using flammable liquids near the appliance;
- Using adaptors, multiple sockets and/or extension cords;
- Attempting to install or repair the appliance without the assistance of qualified personnel.

WARNING- Accessible parts will become hot when in use. To avoid burns and scalds children should be kept away

During use the appliance becomes hot, Care should be taken to avoid touching heating elements inside the oven.

Qualified personnel must be contacted in the following cases:

- Installation (following the manufacture's instructions);
- When in doubt about operating the appliance;
- Replacing the electrical outlet when it is not compatible with the plug for the appliance.

Service Centres authorized by the manufacturer must be contacted in the following cases:

- If in doubt about the soundness of the appliance after removing it from the packaging;
- If the power supply cord has been damaged or needs to be replaced;
- If the appliance breaks down or functions poorly; ask for original spare parts.

It is a good idea to do the following:

- Only use the appliance to cook food, nothing else;
- Check the soundness of the appliance after it has been unpacked;
- Disconnect the appliance from the electrical mains if it is not functioning properly and before cleaning or performing maintenance;
- When the appliance is not used for an extended period of time, cut off the supply of power and close the gas cock (if present);
- Use cooking gloves to place cookware in the oven or when removing it;
- Always grasp the oven door in the centre because the ends may be hot due to the escape of hot air;
- Make sure that the control knobs are on the "o" setting when the appliance is not in use;
- Cut the power supply chord after disconnecting it from the mains when you decide not to use the appliance any longer.

The manufacturer may not be held responsible for any damage due to: incorrect installation, improper, incorrect and irrational use.

During operation, the oven glass door and adjacent parts of the appliance become hot. Make sure, therefore, that children do not touch the appliance.

WARNING: The appliance and its accessible parts become hot during use. Care should be taken to avoid touching heating elements.

Children less than 8 years of age shall be kept away unless continuously supervised.

This appliance can be used by children aged from 8 years and above and persons with reduced physical, sensory or mental capabilities or lack of experience and knowledge if they have been given supervision or instruction concerning use of the appliance in a safe way and understand the hazards involved. Children shall not play with the appliance. Cleaning and user maintenance shall not be made by children without supervision.

Children should be supervised to ensure that they do not play with the appliance.

For greater safety, an additional child-safety device is available from our Head Office and our Authorised Service Centres (see enclosed list). When ordering this, please give the code: BAB-followed by the appliance model. The model is stamped on the plate which is visible on the front part of the oven upon opening the door.

Disassembling/assembling the oven door

Oven structure

The Open space oven has a capacity of 100 litres and offers users the option of cooking on 6 shelves at the same time or cooking large quantities which would not necessarily be possible in a traditional oven.

! The first time you use your appliance , heat the empty oven with its door closed at its maximum temperature for at least half an hour . Make sure that the room is well ventilated before switching the oven off and opening the oven door .The appliance may emit a slightly unpleasant odour caused by protective substances used during the manufacturing process burning away.

!Never put objects directly on the bottom of the oven ; this will prevent the enamel coating from being damaged.

! Always place cookware on the rack (s) provided.

! We suggest not opening the door when cooking foodstuffs which require leavening , so as to not compromise cooking results.

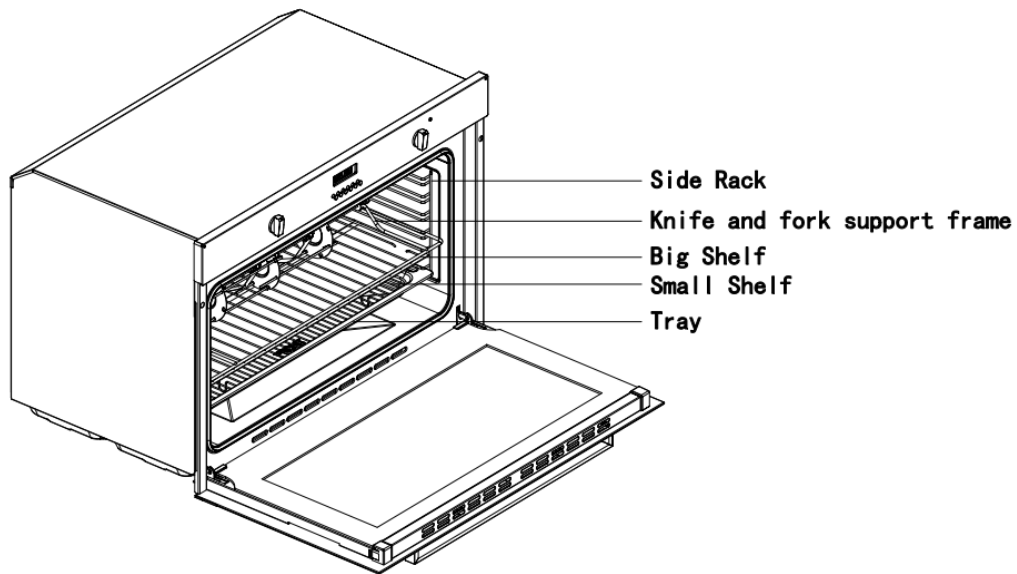

Close-up View

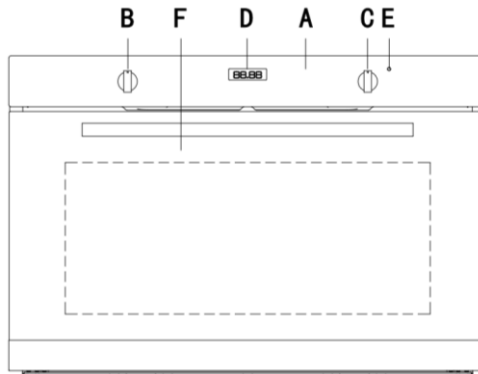

A. Control Panel

B. Knob for selecting the cooking features.

C. Knob for adjusting the cooking temperature.

D. Electronic cooking programmer

E. Function of light – When the light is on, it indicates that the oven is heating. It will turn off when the temperature setting has been reached.

F. Glass oven door

How To Use Your Appliance

The "Maxioven" oven combines in a single appliance the advantages of traditional convection ovens with those of modern forced air ventilation ovens. It is an extremely versatile appliance that allows you to easily and safely choose between 9 different cooking modes. The selection of the various functions can be obtained by putting the programmer to the manual position or setting a beginning/end of cooking program (see specific chapter on page 5) and successively by turning the selector (B) and thermostat (C) knobs on the control panel.

You can choose all the functions:

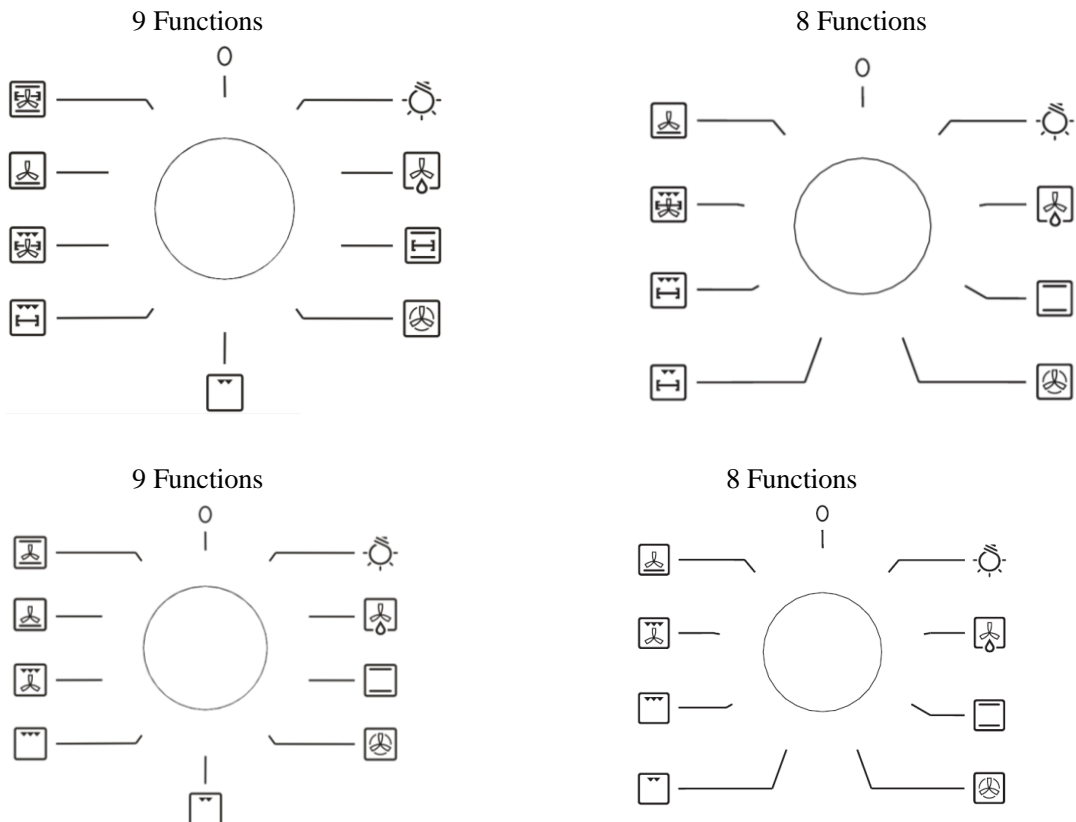

Oven light

When the selector knob is in any position other than the “0” position, the oven light comes on.

Attention: The first time you use the oven we recommend that you set the thermostat on the highest setting and leave the oven on for about a half an hour with nothing in it. Then, open the oven door and let the room air. The odour that is often detected during this initial use is due to the evaporation of substances used to protect the oven during storage and until it is installed.

To thaw

Select this function to thaw more delicate foods. In this mode you use only the cold air circulation.

The thermostat light (E)

This indicates that the oven is heating up. When the light goes out, the required temperature has been reached. When the light alternately comes on and goes out, it means that the thermostat is working properly to maintain the oven temperature.

Convection Mode 、

Set the thermostat knob (c) between 50°C and 250°C.

The outer heating elements at both the top and the bottom of the oven will come on. The heat is distributed uniformly from top to the bottom. The convection mode is recommended for preparing meat-based dishes featuring of liquids. It still remains the best cooking mode for dry pastries and fruit in general. When cooking in convection mode, only use one dripping-pan or cooking rack at a time, otherwise the heat distribution will be uneven. Select from among the various rack heights based on whether the dish needs more or less heat from the top or bottom.

Ventilation Mode

Set the thermostat knob (C) between 50°C and 250°C. The circular heating element and the fan will come on. Since the heat remains constant and uniform throughout the oven, the air cooks and browns food uniformly over its entire surface. With this mode, you can also cook various dishes at the same time, as long as their respective cooking temperatures are the same. A maximum of 2 rack levels can be used at the same time. This cooking mode is ideal for au gratin dishes or those which require an extended cooking time.

Moreover, the excellent heat distribution makes it possible to use lower temperatures when cooking roasts. This results in less loss of juices, meat which is more tender and a decrease in the loss of weight for the roast. The ventilated mode is especially suited for cooking fish, which can be prepared with the addition of a limited amount of condiments, thus maintaining their flavour and appearance. The ventilated mode can also be used to thaw white or red meat, fish and bread by setting the temperature to 80°C-100°C

Grill

Important: do not set thermostat knob (C) to over 200°C. During grilling, keep the oven door closed. Food is cooked in the grill by the downward thermal rays produced by an incandescent electric heating element. The high, direct grill temperature immediately browns meat, thus stopping juice dispersion and keeping meat more tender. The grill is particularly recommended for cooking dishes requiring a high superficial temperature.

Maxi grill 、

Important: do not set the thermostat knob (C) to over 200°C. During grilling, keep the oven door closed. Both of the heating elements of the grill are activated. For more intensive grilling, select this function.

Ventilated Maxi grill 、

Important: do not the thermostat knob (C) to over 200°C. During grilling, keep the oven door closed. Both of the heating elements of the grill are activated, as well as the fan and all grill components. This combination of features increases the effectiveness of the thermal radiation of the heating elements through forced air circulation of the air throughout the oven. This helps prevents foods from burning on the surface, allowing the heat to penetrate into the food.

Gentle pastry oven





Set the thermostat knob (C) between 50°C and 250°C. The lower heating element and the fan come on. This setting is ideal when cooking delicate foods, especially pastries that need to raise, because the heat rising from the bottom facilitates leavening. Please note that with this feature it takes a rather long time to reach higher temperatures in the oven. Therefore, if high temperatures are needed, we recommend that you use the "Conventional" setting.

Ventilated convection Mode 、

Set the thermostat knob (c) between 50°C and 250°C.

The outer heating elements at both the top and the bottom of the oven are activated, as well as the fan. Based on the convection model, This combination of features increases the effectiveness of the thermal radiation of the heating elements through forced air circulation of the air throughout the oven. This helps prevents foods from burning on the surface, allowing the heat to penetrate into the food.

Multi-Skewer Rotisserie

1. Turn support 1 of gear box to a suitable angle, Connect gear box 2 to motor M as Fig. A.
2. Install rotisserie kit as Fig. A and B. Insert one end of rotisserie to gear box 2, and place another end to position 1.
3. Start the motor by turning the knob to the grill setting    .

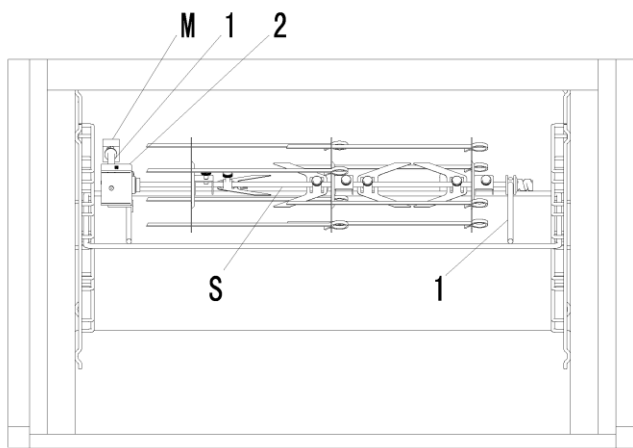

Fig. A

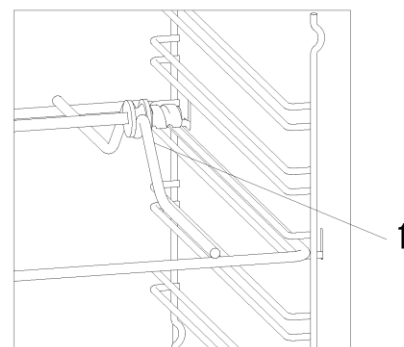

Fig. B

INSTRUCTIONS FOR USE OF CONTROL DEVICES

1 Timers

Our ovens are fitted with different types of timers (some with mechanical time and the others with electronic timer), The following function for your reference according to your oven.

2 MINUTES COUNTERS

Turn the knob clockwise to set the desired cooking time.

The minutes minder can be adjusted from 1 to 60 minutes. A sound signal will inform you that the chosen time is

up (Fig. 13).and you can choose another one ,it can be adjusted from 1 to 120 minutes.

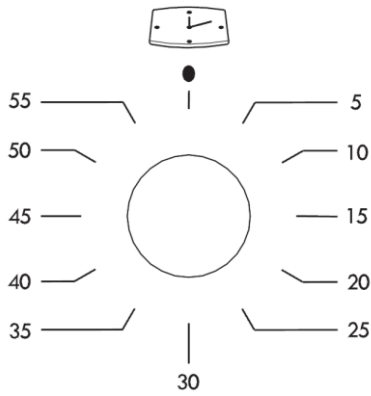

Fig. 13

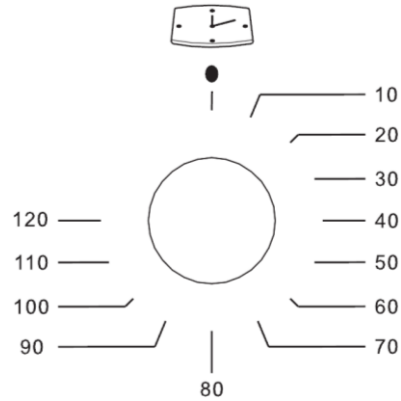

Fig. 14

<<LED>>PROGRAMMER (Fig.18) (6 keys Electronic Timer)

1 Features

24 hours clock with automatic programmer and minutes counter

2 Functions

Cooking time. cooking end time, manual position, clock, minutes counter, times to be set up to 23 hours 59 minutes.

3 Display

4-figures, 7segments display for cooking times and time of day.

Cooking time and manual function =saucepan symbol

Automatic function =AUTO

Minutes counter =bell symbol

The symbols light up when the corresponding function are selected

4 Setting

To set ,press and release the desired function ,and within 5 seconds set the time with +and –buttons .

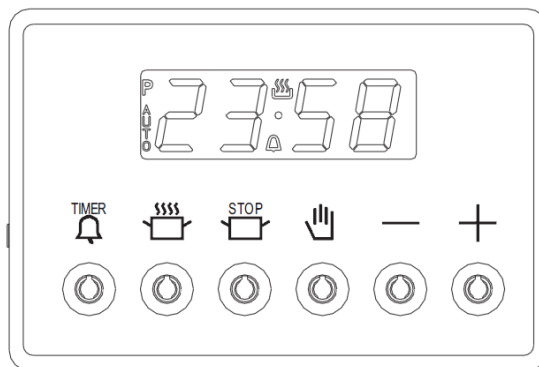

Fig. 18

| | |
|--|-----------------|
| | Minutes counter |
| | Cooking time |
| | End time |
| | Manual |
| | Subtract time |
| | Add time |

TASTO +e

+and buttons .

the +and –buttons increase or decrease the time at a speed depending on how long button is pressed

Setting the time

press any two buttons (cooking time ,end time ,minutes counter) at the same time ,and +or –button to set the desired time .this deletes any previously set program

The contacts are switched off and the AUTO symbol flashes.

5 Manual use

By pressing the manual button the relay contacts switch on, the AUTO symbol switches off and saucepan symbol lights up.

Manual operation can only be enabled after the automatic program is over or it has been cancelled.

6 Automatic use

Press the cooking time or end time button to automatically form the manual to the automatic function.

7 Semi-automatic use with cooking time setting

Press the cooking time button and set the desired time with +or -, the AUTO and cooking time symbols light up continuously. The relay switches on immediately. When the cooking end time corresponds to the time of day, the relay and the cooking time symbol switch off. the sound signal rings and the AUTO symbol flashes.

8 Semi-automatic use with end time setting

Press the end time button. The time of day appears on the display. Set the cooking end time with +button. The AUTO and cooking time symbols light up continuously. The relay contacts switch on. When the cooking end time corresponds to the time of day , the relay and the cooking time symbol switch off. When the cooking time is up. The AUTO symbol flashes, the sound signal rings and both the relay and the cooking time button switch off.

9 Automatic use with cooking time and end time setting

Press the cooking time button and select the length of the cooking time with +or –button. The AUTO and cooking time symbols light up continuously. The relay switches on. By pressing the cooking end time button the next cooking end time appears on the display. Set the cooking end time with +button. The relay and the cooking time symbol switch off .the symbol lights up again when the time of day corresponds to the cooking start time. When the cooking time is up, the AUTO symbol flashes, the sound signal rings, the cooking time symbol and the relay switch off

10 Minutes counter

Press the minutes counter button and set the cooking time with +or –button.

The bell symbol lights up when the minutes counter is operating, when the set time is up, the sound rings and the bell symbol switches off.

11 Sound signal

The sound signal starts at the end of a programmer or of the minutes counter function and it lasts for 15minutes.

To stop it, push any one of the functions buttons.

12 Start programme and check

The programmer starts 4seconds after it has been set. The programmer can be checked at any time by pressing the corresponding button.

Setting error

A setting error is made if the time of day on the clock falls within the cooking start and end times. To correct the setting error, change the cooking time or cooking end time the relays switch off when a setting error is made.

13 Cancelling a setting

To cancel a setting, press the cooking time button and then press the –button until 00 00 appears on the display. A set programmer will automatically cancel on completion.

Operating instructions for Electronic Timer (3 keys)

1 Functional description-Overview

The operation of this timer is done 3 buttons. The functions of the buttons are:



With this arrangement it is possible to select the following four functions:

- Minute minder
- Operation period
- Operation stop
- Time-of-day

These modes can be selected by repeatedly pressing the mode button. The desired time for minute minder, operation period, operation stop or time-of-day can be set with the “+”and “-“buttons.

As an option, the duration of a pyrolysis can be controlled, if an oven features such function.

2 Programming

2.1 Draft of the display

The LED display is separated in the following way:

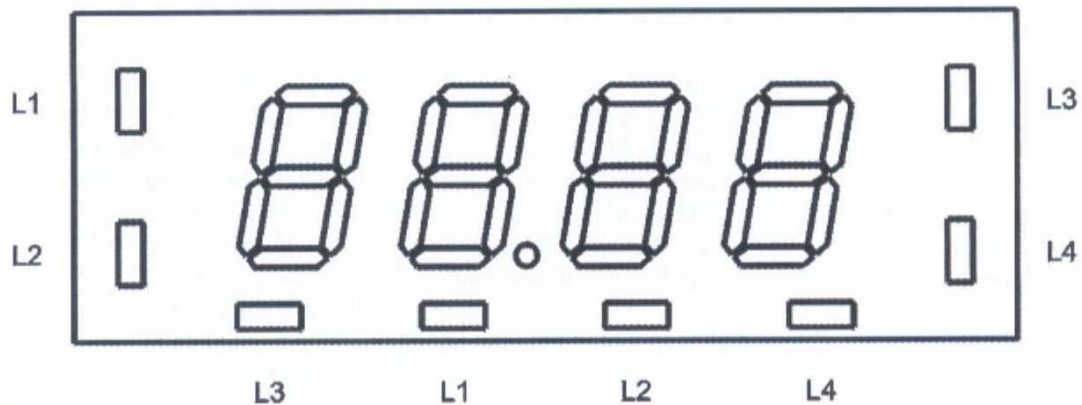

New picture with frame outside

L1: Operation period

L2: Operation end

L3: Minute minder

L4: Adjust time-of-day

Depending on the variant in hand either the 4 LEDs at the side of the display or the 4 LEDs below are active for displaying the mode.

2.2.1 Time of day

When connected to mains supply the display shows 12.00 o'clock and the LED L4 flashes. As long as it is flashing, it is possible to adjust the time via the plus and minus buttons.

Once the time is adjusted, it is stored approx. 5 seconds after the last operation, the LED L4 goes dark again.

It is possible to adjust the time-of-day by pressing the mode button until L4 flashes, then the time-of-day can be adjusted.

2.2.2 Minute minder (interval time)

In order to set the interval time, the “Mode” button has to be pressed repeatedly until LED L3 is flashing. Then the interval time can be set between 0.01 and 2.30 h by using the plus and minus buttons. After setting the interval time, it remains displayed and the LED L3 is now illuminated steadily. After the interval time has run down, the alarm signal sounds (2 beeps every 2 seconds) and the LED L3 is flashing again. Pressing any of the buttons stops the signal and the flashing, the LED goes dark and the display reverts to the time-of-day. If the alarm is not stopped manually, it terminates automatically after 2 minutes.

The minute minder can be applied at any time while other functions are operative.

2.2.3 Operation period

In order to set an operation period, the mode button has to be pressed repeatedly until the LED L1 is flashing. Then the desired operation period (time frame between 0.01h and 10.00h) can be set using the plus and minus buttons. Once adjusted, it will be stored after approx. 5 seconds, the LED L1 remains illuminated steadily, and the set time starts running down. The display reverts to the time-of-day. As soon as the operation period has ended, the relay opens and the alarm signal sounds (4 beeps every 2 seconds) and the LED L1 is flashing again. Pressing any of the buttons stops the signal and the flashing, the LED goes dark and the relay closes again. If the alarm is not stopped manually, it terminates automatically after 2 minutes.

2.2.4 Operation stop

In order to set an operation stop, the mode button has to be pressed repeatedly until the LED L2 is flashing. Then the desired operation stop, which is limited to a point being maximally 23.59 h in the future, can be set using the plus and minus buttons. Once adjusted it will be stored after approx. 5 seconds, and the LED L2 remains illuminated steadily. The display reverts to the time-of-day. As soon as the operation stop has been reached, the relay opens and the alarm signal sounds (4 beeps for 2 minutes) and the LED L2 is flashing. Pressing any of the buttons stops the signal and the flashing, the LED goes dark and the relay closes again.

It is possible to combine the duration and end time in order to program a delayed mode. To do this, both the operation period and operation stop time have to be set (set above). LED L1 and L2 are illuminated and the baking process will start at a point in time “operation stop minus operation period”. If a baking process ought to be finished at 12.00 and shall last 1.30 h, both times have to be set in the respective modes, and the timer will switch on the oven at 10.30.

The timer is capable to avoid conflicts during the programming. (E. g. with an operation period of 60 minutes resp. 1.00 hr set, and the time-of-day being 11.34 o'clock, then the operation stop can be earliest at 12.34 o'clock.)

Please note:

A running program can be checked and corrected at any time. In order to avoid conflicts, it is not possible to set the time of day when an automatic program is active.

Practical Cooking Advice

Preheating

If the oven must be preheated (generally this is the case when cooking leavened foods) the " Ventilation mode " as possible in order to save on energy.

Once the food has been placed in the oven. The most appropriate cooking mode can then be selected.

Using the grill

The Multifunction oven offers you three different grilling modes

Use the " Grill " setting for grilling in perfect mode small portions like toasted sandwiches, hotdogs, etc., to perfection.

The " Maxigrill " position is the best for grilling foods rapidly. For a better distribution of heat, not only to

brown the surface but also to cook the bottom part, select " Ventilated Maxigrill " function.

This mode can also be used for browning foods at the end of the cooking process.

Important: always use the grill with the oven door closed. This will allow you both to attain excellent results and to save energy

When using any of the three grilling modes , it is recommended that the thermostat knob be turned to the 175°C, as it is the most efficient way to use the grill (which utilizes infrared rays).

If necessary, however, the thermostat can be set to lower temperatures by simply turning the knob to the desired setting.

When utilizing the grill, place the rack at the lower levels (see cooking table). To catch grease or fat and prevent smoke, place a dripping-pan at the bottom rack level.

Baking pastries

When baking pastries, always place them in the oven after it has been preheated. Make sure you wait until the oven has been preheated thoroughly (the red " E " light will turn off). Do not open the door while the pastry is cooking in order to prevent it from dropping.

Batters must not be too runny, as this will result in prolonged cooking times. In general:

| |
|---|
| Pastry is too dry |
| Increase the temperature by 10°C and reduce the cooking time. |

| |
|--|
| Pastry dropped |
| Use less liquid or lower the temperature by 10°C |

| |
|---|
| Pastry is too dark on top |
| Place it on a lower rack, lower the temperature, and increase the cooking time. |

| |
|--|
| Cooked well on the inside but sticky on the outside |
| Use less liquid, lower the temperature, and increase the cooking time. |

| |
|--|
| The pastry sticks to the pan |
| Grease the pan well and sprinkle it with a dusting of flour. |

| |
|--|
| I used more than one level and they are not all at the same cooking point |
| Use a lower temperature setting. It is not necessary to remove the food from all the racks at the same time. |

Cooking Pizza

For best results when cooking pizza use the " Ventilation mode " :

- Preheat the oven for at least 10 minutes;
- Use a light aluminium pizza pan, placing it on the broiler supplied with the oven. If the dripping-pan is used, this will extend the cooking time, making it difficult to get a crispy crust;
- Do not open the oven door frequently while the pizza is cooking;
- If the pizza has a lot of toppings (three or four), it is recommended that the mozzarella cheese be placed on top halfway through the cooking process;

Cooking Fish and Meat

Meat must weigh at least 1 Kg in order to prevent it from drying out. When cooking white meat, fowl and fish,

use low temperature settings (150°C-220°C). For red meat that should be well done on the outside while tender and juicy in the inside, it is a good idea to start with a high temperature setting (200°C-220°C) for a short time, then turn the oven down afterwards. In general, the larger the roast, the lower the temperature setting. Place the meat on the centre of the rack and place the dripping pan beneath it to catch the fat.

Make sure that the rack is inserted so that it is in the centre of the oven. If you would like to increase the amount of heat from below, use the low rack heights. For savory roasts (especially duck and wild game), dress the meat with lard or bacon on the top.

STATIC OVEN COOKING

| Type of dish | Temperature | Cooking time | Type of dish | Temperature | Cooking time |
|-----------------------|-------------|--------------|---------------------------|-------------|--------------|
| Pastries and cakes | (°C) | minutes | Meat | (°C) | hours |
| Fruit pie | 130 | 60-70 | Turkey (4-8 kg) | | |
| Meringues | 130 | 30-40 | Goose (4-5 kg) | | |
| Sponge cake | 150 | 20-30 | Duck (2-4 kg) | | |
| Angel cake | 160 | 40-50 | Capon (2 1/2-3 kg) | | |
| Madeira cake | 160 | 40-50 | Braised beef (1-1 1/2 kg) | | |
| Chocolate cake | 170 | 30-40 | Leg of lamb | | |
| Flat sweet loaf | 170 | 40-50 | Roast hare (2 kg) | | |
| Puffs | 200 | 15-20 | Roast pheasant | | |
| Flaky pastry biscuits | 200 | 15-20 | Chicken(1-1 1/2 kg) | | |
| Mille feuilles | 200 | 15-20 | Fish | 200 | Minutes |
| Short pastry | 200 | 15-20 | | | 15-25 |

Grilling

| Type of dish | Cooking time (minutes) | Position of shell |
|----------------------------|------------------------|----------------------------|
| Chops (0.5 kg) | min. 25 | 3 rd guide rail |
| Sausages | min. 15 | 2 nd guide rail |
| Grilled chicken (1 kg) | min. 60 | 1 st guide rail |
| Veal on the spit (0.6 kg) | min. 60 | - |
| Chicken on the spit (1 kg) | min. 60 | - |

Cooking times may vary according to the nature of the foods, their homogeneity and their volume. When cooking a certain food for the first time, it is advisable to choose the lowest values in the cooking time range given in the table and then increase them if necessary.

The 1st guide rail is understood as being the lowest position.

USEFUL NOTES FOR COOKING

In the following table, some indicative hints for cooking:

| FAULTS | CAUSES | REMEDIES |
|---|---------------------------------|---|
| The upper crust is dark and the lower part too pale | Not enough heat from the bottom | <ul style="list-style-type: none"> - Use the natural convection position - Use deeper cake tins - Lower the temperature - Put the cake on a lower shelf |

| | | |
|--|--------------------------------|---|
| The lower part is dark and the upper crust too pale | Excessive heat from the bottom | <ul style="list-style-type: none"> - Use the natural convection position - Use lower side tins - Lower the temperature - Put the cake on a higher shelf |
| The outside is too cooked and the inside not cooked enough | Too high temperature | - Lower the temperature and increase the cooking time |
| The outside is too dry even though of the right color | Too low temperature | - Increase the temperature and reduce the cooking time. |

Technical Specifications

| | |
|---------------------|------------|
| Electric oven size: | litres 125 |
| Oven size | |
| Width | mm. 770 |
| Depth | mm. 418 |
| Height | mm. 379 |

Powers absorbed in accordance with models

| | | | Accessories according to models | | |
|------------------------|----------|--------------------------|---------------------------------|---------------------|--------|
| Oven lower heating el. | 1300Watt | Medium grill heating el. | 2000 Watt | synchronomotor | 4 Watt |
| Oven upper heating el. | 1050Watt | Total grill heating el. | 1050+2000 Watt | Shaded motor (back) | 33Watt |
| Oven light | 25Watt | Circle heating el. | 2 × 1400Watt | Shaded motor (top) | 25Watt |

Voltage end frequency: 220-240V,50/60Hz
Power supply Max: 2800W(220V)-3400W(240V)-